

CAMPERA IGNIFUGA PARKA O LARGA FR 93/5/2 6 OZ (93% META ARAMIDA-5% PARA ARAMIDA-2% ANTIESTATICO)



MOLDERIA: Descripción del producto

 **MAXIMO  
ESFUERZO**

FECHA: 16/07/2024

COD: 222

HOJA: 1 de 4

FRENTE



ESPALDA

COLOR: Navy



CAMPERA IGNIFUGA PARKA O LARGA FR 93/5/2 6 OZ

ATPV (ASTM F1959) : 7.6 cal/cm<sup>2</sup>  
NFPA 2112 (FUEGO REPENTINO)  
NFPA70E (ARCO ELECTRICO NIVEL 2)



CARACTERISTICAS PRINCIPALES:

- Proteccion a exposiciones mas largas y temperaturas elevadas.
- Resistencia inherente al calor y llamas.
- Proteccion inherente. No se pierde por el lavado o desgaste.
- Resistente a roturas y abrasiones.





MOLDERIA: Campera vista frontal



FECHA: 16/07/2024

COD: 222

HOJA: 2 de 4

Cartera cubre cierre con 4 broches snap ubicados de manera equidistante

Capucha cubre cuello con 2 broches snap

Cierre con tira cierre

Etiqueta de composición y talle centradas en cuello

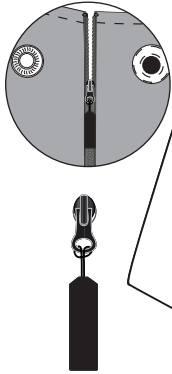

Puño ajustable con broche snap.  
Presillas de 11cm x 3 cm  
(tela doble y pespunte simple)

El cierre no llegará al ruedo

Bolsillo interior  
Vista interna

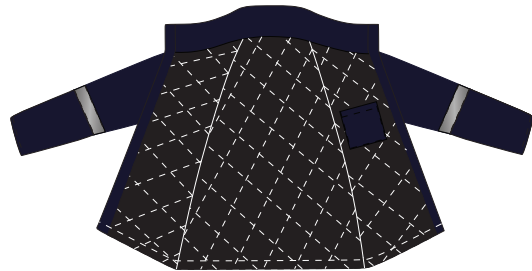
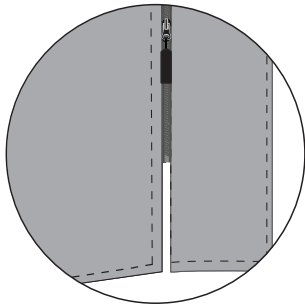

Interior de matelasse



MOLDERIA: Campera vista trasera



FECHA: 16/07/2024

COD: 222

HOJA: 3 de 4

CAPUCHA  
DESMONTABLE

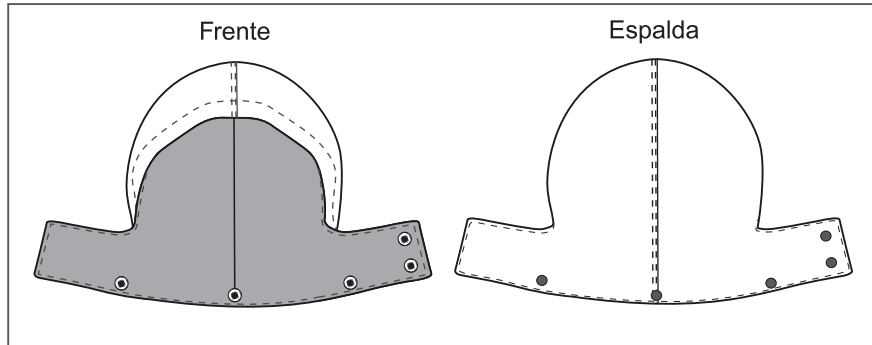

Reflectivo amarillo  
en mangas  
y espalda

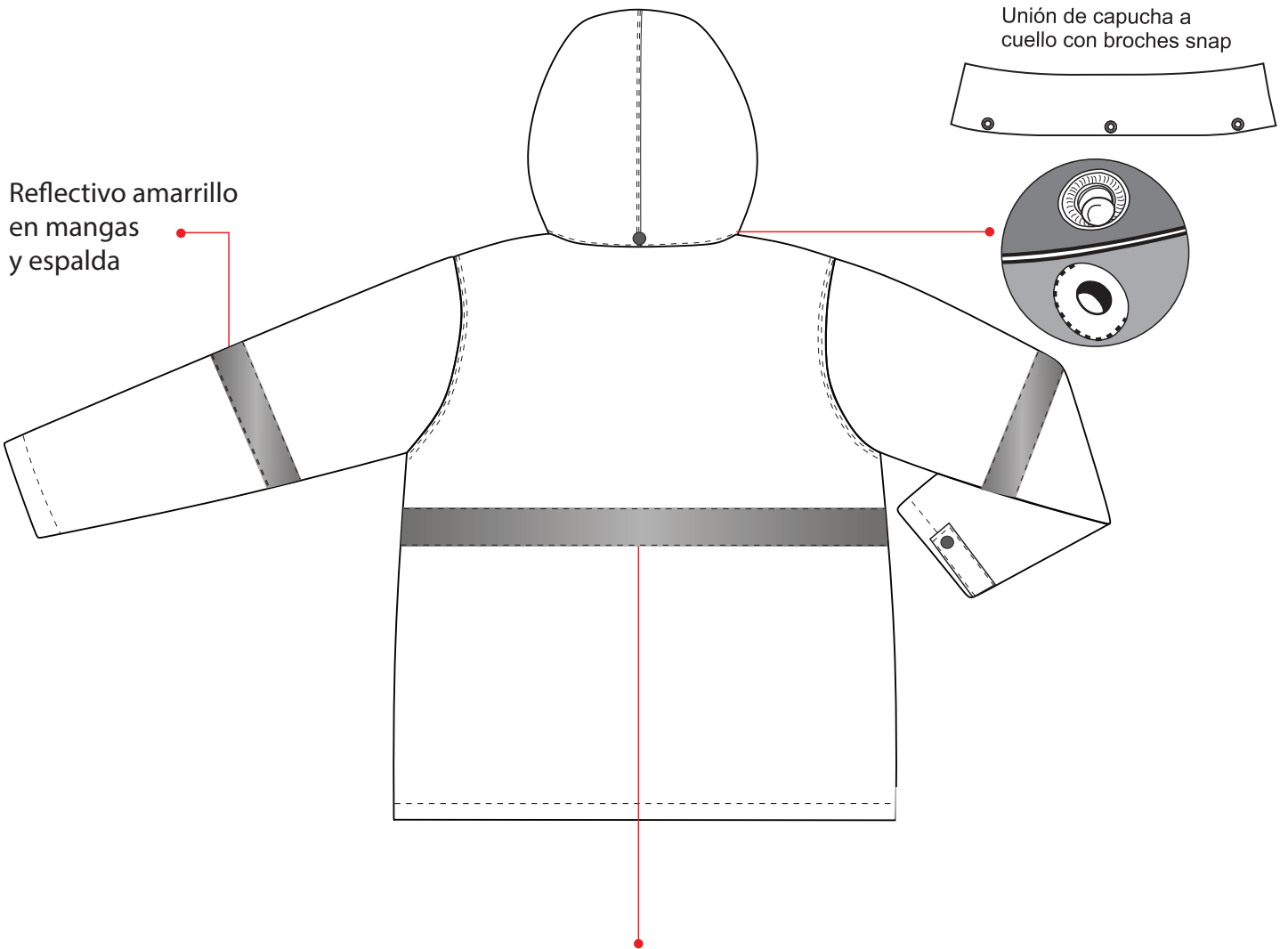

Unión de capucha a  
cuello con broches snap

Cinta reflectiva gris en  
todo el ancho de espalda

CAMPERA IGNIFUGA PARKA O LARGA FR 93/5/2 6 OZ (93% META ARAMIDA-5% PARA ARAMIDA-2% ANTIESTATICO)

MOLDERIA: Medidas

**MAXIMO  
ESFUERZO**

FECHA: 16/07/2024

COD: 222

HOJA: 4 de 4



### TABLA DE MEDIDAS

	DESCRIPCION	S	M	L	XL	2XL	3XL	4XL
A	ANCHO DE TORAX	54	58	62	66	70	74	78
B	LARGO DE ESPALDA	81	82	83	84	85	86	87
C	ANCHO DE HOMBRO	42	46	50	54	58	62	66
D	LARGO DE MANGA	64	65.5	67	68.5	70	71.5	73

